



Standard Specification for Manually Operated Front Wheel Retention Systems for Bicycles¹

This standard is issued under the fixed designation F 2680; the number immediately following the designation indicates the year of original adoption or, in the case of revision, the year of last revision. A number in parentheses indicates the year of last reapproval. A superscript epsilon (ϵ) indicates an editorial change since the last revision or reapproval.

1. Scope

1.1 This specification covers the standard for front wheel retention systems for all bicycles equipped with manually operated retention systems such as a quick release.

1.2 This specification is only for bicycles equipped with manually operated retention systems, and does not apply to tool-operated wheel fastening systems.

1.3 The intent of this specification is to define the performance of primary and secondary wheel retention systems, with the focus on preventing unintended wheel separation.

1.4 The values stated in SI units are to be regarded as standard. No other units of measurement are included in this standard.

1.5 *This standard does not purport to address all of the safety concerns, if any, associated with its use. It is the responsibility of the user of this standard to establish appropriate safety and health practices and determine the applicability of regulatory limitations prior to use.*

2. Terminology

2.1 *Definitions of Terms Specific to This Standard:*

2.2 *adult bicycle, n*—bicycle designed for, and marketed to, adult riders.

2.3 *bicycle fork (fork), n*—mechanism between the head tube and front hub axle, including some or all of the following components; the steerer tube, crown, fork blades, triple clamps, shock absorbers, lower tubes, upper tubes and dropouts (fork ends).

2.4 *direction of removal of the wheel from the fork, n*—direction, when both primary and secondary wheel retention systems are disengaged, that provides the least resistance to wheel and fork separation or wheel removal.

2.5 *dropout (fork end), n*—fork component used to support, or mount, the front wheel at the axle.

2.6 *manually operated, adj*—without the use of tools.

2.7 *primary retention, n*—system that keeps the bicycle wheel connected to the bicycle fork for riding.

2.8 *primary retention system in the unlocked position, n*—position where, (1) if a quick release cam is used, the cam is opened as far as possible or (2) if a turning style system such as a wing nut or another non-cam style system is used, the manual lever is loosened 360°.

2.9 *quick release mechanism, n*—lever-actuated cam mechanism that connects and retains the bicycle front wheel to the bicycle fork.

2.10 *secondary retention, n*—system that retains the bicycle wheel in the dropouts when the primary retention system is in the open (unlocked) position.

2.11 *wheel hub, n*—assembly consisting of an axle connected by bearings to a hub shell, to which the spokes attach, and permitting the shell to revolve around the axle.

3. Performance Requirements

3.1 Bicycles equipped with manually operated primary retention systems shall be equipped with secondary retention systems.

3.2 The primary retention system shall prevent relative motion between the front wheel axle and the front fork when tested as shown in Fig. 1 by the methods described in 4.1.1.

3.3 The secondary retention system shall prevent front wheel removal or partial separation when tested by the methods described in 4.1.2. An example of one type of front wheel partial separation is shown in Fig. 2.

3.4 Manually operated wheel retention systems shall not be used on bicycles with 20-in. (51-cm) diameter wheels or smaller (excluding adult bicycles).

4. Test Methods

4.1 *Test Setup*—Assemble and adjust the primary and secondary retention systems according to the manufacturers instructions. Remove the braking system entirely or set to the state for wheel removal. With no tire on the wheel, and the fork non-rotatably mounted only by the steerer tube:

¹ This specification is under the jurisdiction of ASTM Committee F08 on Sports Equipment and Facilities and is the direct responsibility of Subcommittee F08.10 on Bicycles.

Current edition approved Feb. 1, 2009. Published March 2009.

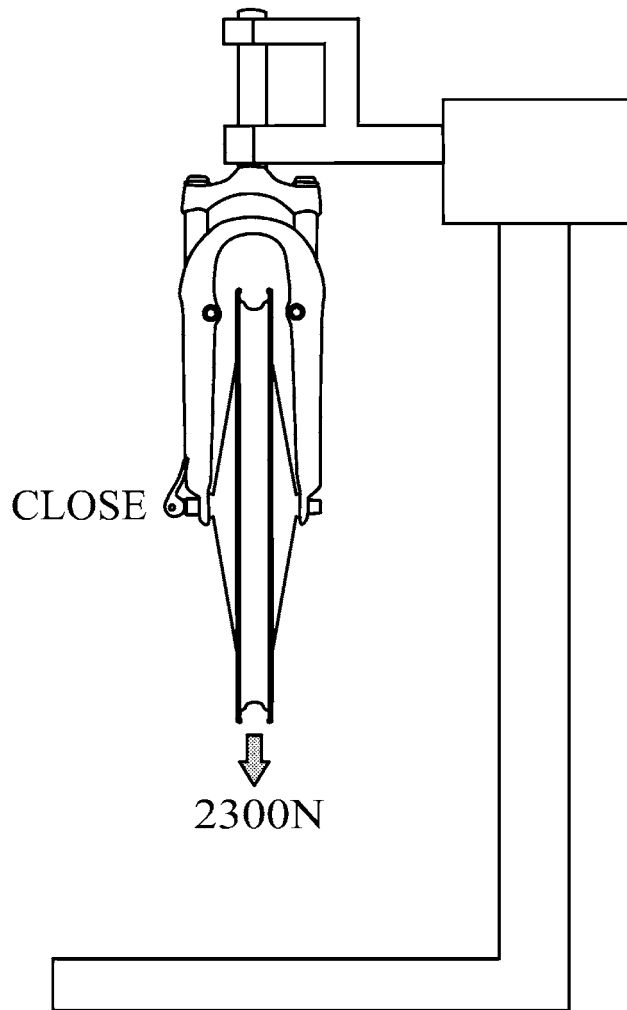

FIG. 1 Typical Primary Retention Test Apparatus

4.1.1 *Primary Retention Test*—Lock the primary retention system for the riding condition and apply a force of 2300 N that is distributed symmetrically on the axle for a period of 1 min in the direction of removal of the wheel from the fork.

4.1.2 *Secondary Retention Test*—As shown in Fig. 3, with the primary retention system in the unlocked position, apply a Force “A” of 200 N distributed symmetrically on the axle in the direction of the removal of the wheel from the fork. While applying Force “A”, apply an additional 100 N Force “B” on the wheel rim as follows:

(1) *Location*—At the intersection of the extension of the Force “A” vector and a rim of maximum size compatible with the fork.

(2) *Direction*—Applied on the wheel rim in a direction parallel to the hub axle.

(3) *Duration*—Apply force for 1 min, then reduce Force “B” to zero as quickly as possible while maintaining Force “A”. Then reduce Force “A” to zero.

4.1.2.1 Repeat 4.1.2 with Force “B” applied on the opposite side of the wheel (as shown in Fig. 4).

4.1.2.2 If the wheel mounting system allows the wheel to be mounted in a reversible manner, re-mount the wheel reversed in the bicycle fork, an example of which is shown in Fig. 5.

4.1.2.3 Repeat the test described in 4.1.2 with the assembly shown in Fig. 5.

4.1.2.4 Repeat the test described in 4.1.2.1 with the assembly shown in Fig. 6.

5. Rejection

5.1 Bicycle front wheel retention systems that fail to meet the performance requirements of this specification will be rejected.

6. Keywords

6.1 bicycle fork; bicycle quick release; bicycle wheel; dropout; fork end; wheel hub; wheel retention

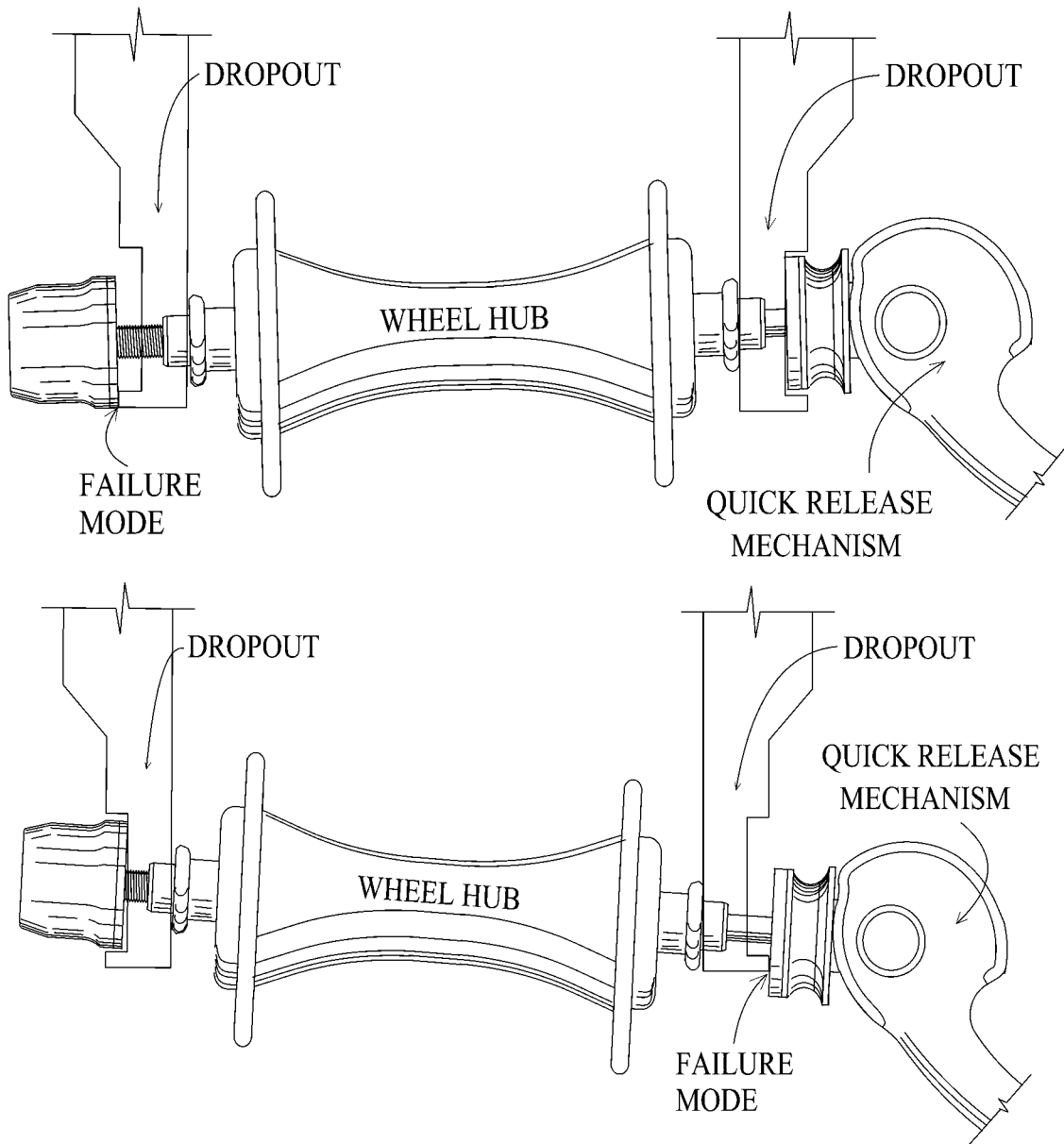

FIG. 2 Failure Mode Examples